

26215-84

4-2003

# 26215-84

Hand-saws.  
Specifications

79.120.20  
48 3322

01.07.85

( , .JV° 1).

1. ,

- 1.1. :
- 1 — ;
- 2 — ;
- 3 — .

1.2. .1, 2 — .2 .1, 3 — .3 .2.

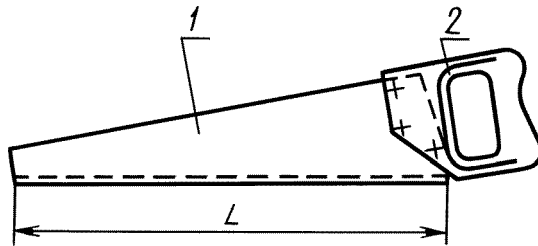

1 — полотно, 2 — ручка

1

1

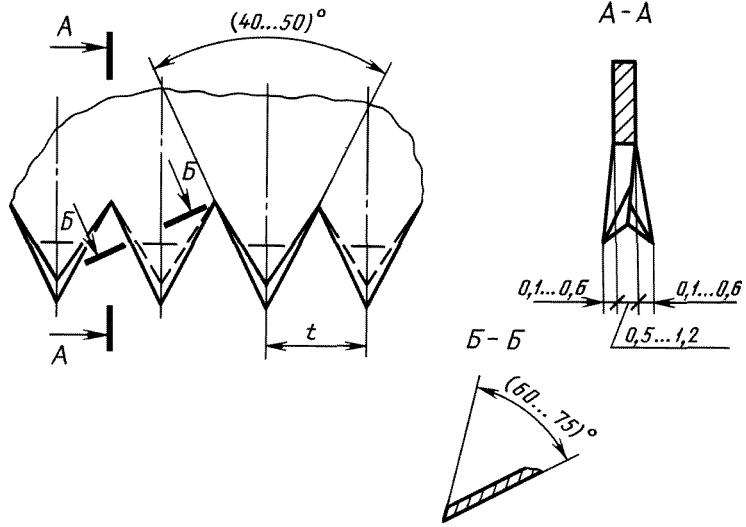

2

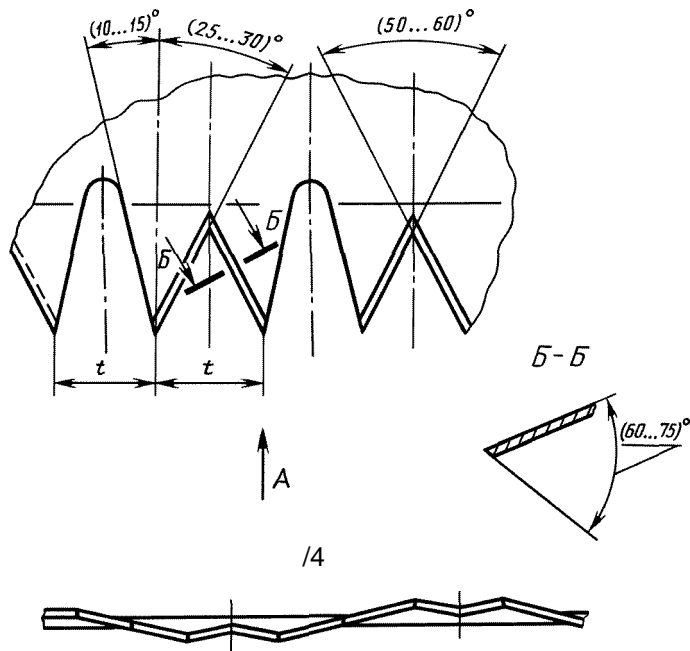

. 1

2

1

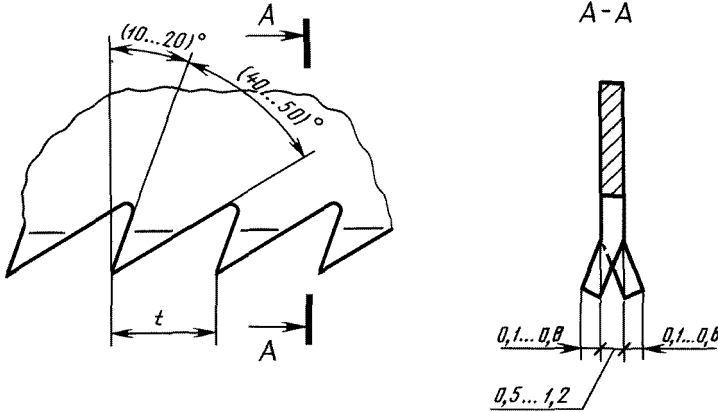

Исполнение 2

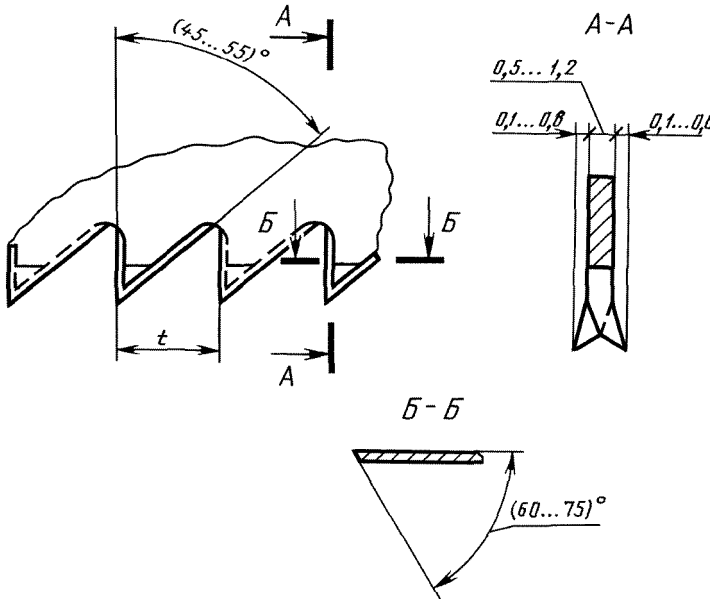

.2



L ± 10	t ± 0,5								
	1,5	2,0	2,5	3,0	3,5	4,0	4,5	5,0	
500	+	+	+	+	+	+	+	+	0,60
525			+	+	+	+	+	+	
550			+	+	+	+	+	+	0,65
575			+	+	+	+	+	+	
600			+	+	+	+	+	+	0,70

1, 1,

500 , 5 :  
1-1-500-5 26215-84.

1.1, 1.2. ( , .JV° 1).

2.

2.1.

2.2.

60 2

14959.

7, 7 , 8, 8 , 8 , 8 , 9 , 10

8 , 9 , 9  
1435,

5950,  
65 ,

2.3.

21996.  
( , . 1).

03—010—02

28804;  
16338;  
1-  
2, 9  
1050.

2695;  
1583;

380

2.4.

( )

0,05

21996.

( , . 1).

2.5.

2.6.

42 ... 52 HRC<sub>3</sub>.

Ra 1,25

2789,

21996.

2.7.

0,2 —

100

21996.

2.8.

2/3

( )

(

), :  
 0,1 ... 0,3 —  
 0,3 ... 0,6 » » » » 3,5 3 5,0 ;  
 0,6 ... 0,8 » » » » 6,0  
 2.6—2.8. ( , .JV° 1).  
 2.9.

2.10.

22 %.

5

5

( , .N° 1).

2.11.

2.12.

9.303

9.306

3

15150.

2.13.

-165

12034

-25

5406

-165

2.12, 2.13. ( , .N° 1).

2.14.

7

9825,

-221

4976

2.15.

IV

9.032,

2

9.104.

( , . 1).

2.16.

490 (50 ).

2.17.

8486

3

450

1,0 -;

3

450 —

1,3 -;

3

450 —

1,5 -;

/?/

400

7016.

/?/

800

7016.

( , . 1).

2.18.

2

15150.

3.

3.1.

2

( , . 1).

3.2.

4.

4.1.

4.2.

( , . ) , 2.4, 2.9, 2.11. . 2.1, 2.12, 2.13, 2.14  
 . 1.2, 2.5, 2.6, 2.7, 2.8, 2.10, 2.15, 2.16  
 . 3.

3

51-90	1 2	8 8	16	0 1	2 2
91-150	1 2	13 13	26	0 3	3 4
151-280	1 2	20 20	40	1 4	4 5
281-500	1 2	32 32	64	2 6	5 7
501-1200	1 2	50 50	100	3 8	7 9
1201-3200	1 2	80 80	160	5 12	9 13
3201-10000	1 2	125 125	250	7 18	11 19

. 3,

. 3.

4.3.

4.2, 4.3. ( , . JV° 1).

4.4.

. 2.4—2.17

4.5.

5.

5.1. ( . 1.2, 2.8)

5.2. ( . 1.2)

5.3. ( . 2.4, 2.9, 2.11—2.14)

5.4. ( . 2.5)

9013

22975.

5.5. ( . 2.6)

9378.

5.6. ( . 2.7)

( , . 1).



5.7.		( . 2.10)	16588	.
5.8.	( . 2.15)			—
9.302,		—	-	.
5.9.			( . 2.16)	
		2-	490 <sup>+49</sup> (50 <sup>+&gt;</sup> )	
			13837	
5.10.		( . 2.17)	,	8486
	22 %.		,	. 2.17
<b>5.9, 5.10. (</b>		<b>, . JV° 1).</b>		
<b>6.</b>				
6.1.			:	
		(	;	)
6.2.		—	9.014,	-1,
				-
6.1. 6.2. (				
6.3.			—	18088.
6.4.				
6.5.		—	2	15150.
		<b>7.</b>		
7.1.				-
7.2.			—	—

1. , -

2. 19.06.84 N° 1974

3. -

9.014-78	6.2
9.032-74	2.15
9.104-79	2.15
9.302-88	5.8
9.303-84	2.12
9.306-85	2.12
380-94	2.3
1050-88	2.3
1435-99	2.2
1583-93	2.3
2695-83	2.3
2789-73	2.6
4976-83	2.14
5406-84	2.13
5950-2000	2.2
7016-82	2.17
8486-86	2.17; 5.10
9013-59	5.4
9378-93	5.5
9825-73	2.14
12034-77	2.13
13837-79	5.9
14959-79	2.2
15150-69	2.12; 2.18; 6.5
16338-85	2.3
16588-91	5.7
18088-83	6.3
21996-76	2.2; 2.4, 2.7
22975-78	5.4
28804-90	2.3

4. 4—93  
, ( 4—94)

5. ( 2003 .) 1, 1989 .( 2—90)

.11.

.11.

02354 14.07.2000.

19.01.2004.

16.02.2004. . . . 1,40. . - . . 0,90.

135 . 807. . 175.

11

, 107076

., 14.

<http://www.standards.ru>

e-mail: [info@standards.ru](mailto:info@standards.ru)

— ."

", 105062

.. 6.

080102